

M1. The mark scheme gives some guidance as to what statements are expected to be seen in a 1 or 2 mark (L1), 3 or 4 mark (L2) and 5 or 6 mark (L3) answer. Guidance provided in section 3.10 of the 'Mark Scheme Instructions' document should be used to assist in marking this question.

Mark	Criteria	QoWC
6	<p>All three aspects (physical, interference and signal carrying properties) covered: A clear discussion of the advantages / disadvantages of the two systems in terms of weight (and in some cases cost). There may also be a suggestion that optical fibres are harder to join together. A comparison of their relative vulnerability to external interference and security.</p> <p>A comparison of the two systems in terms of signal degradation, bandwidth and speed of transmission.</p>	<p>The student presents relevant information coherently, employing structure, style and sp&g to render meaning clear. The text is legible.</p>
5	<p>Two of the three aspects fully covered, with some detail missing from the third.</p>	
4	<p>One aspect fully covered, with some detail missing from the other two</p> <p>Or</p> <p>Two aspects fully covered, with little or no relevant information about the third.</p>	
3	<p>All three aspects partially covered, with some detail missing from each</p>	<p>The student presents relevant information and in a way which assists the communication of meaning. The text is legible. Sp&g are sufficiently accurate not to obscure meaning.</p>

	Or One aspect fully covered, with little or no relevant information about the other two	
2	Two aspects partially covered, with little or no relevant information about the third.	The student presents some relevant information in a simple form. The text is usually legible. Sp&g allow meaning to be derived although errors are sometimes obstructive.
1	One aspect partially covered, with little or no relevant information about the other two.	
0	Little or no relevant information about any of the three aspects.	The student's presentation, spelling punctuation and grammar seriously obstruct understanding.

		copper	optic fibre
<i>Physical</i>	<i>corrosion</i>	<i>Will corrode unless well-protected</i>	<i>Glass doesn't corrode</i>
	<i>weight / cost etc</i>	<i>Copper heavier / more expensive / easy to join</i>	<i>Thinner and less expensive. Harder to join</i>
<i>External interference</i>	<i>security</i>	<i>Can be 'tapped' without breaking cable</i>	<i>Cannot be tapped (unless cable broken into)</i>
	<i>electromagnetic interference</i>	<i>Can pick up noise / cross talk</i>	<i>Immune from noise / can be used in 'noisy' environments</i>
<i>Signal carrying properties</i>	<i>signal degradation / attenuation</i>	<i>High attenuation</i>	<i>Low attenuation but pulses can suffer smearing</i>

	<i>bandwidth / info carrying capacity</i>	<i>Relatively low / fewer channels</i>	<i>greater info-carrying capacity / more channels / possibility of sending more than one signal on optic fibre eg data + talk</i>
--	---	--	---

[6]

M2.(a) (any order)

- 1 free space ✓
- 2 wires (twisted pair, coaxial etc.) ✓
- 3 fibre ✓

3

(b)

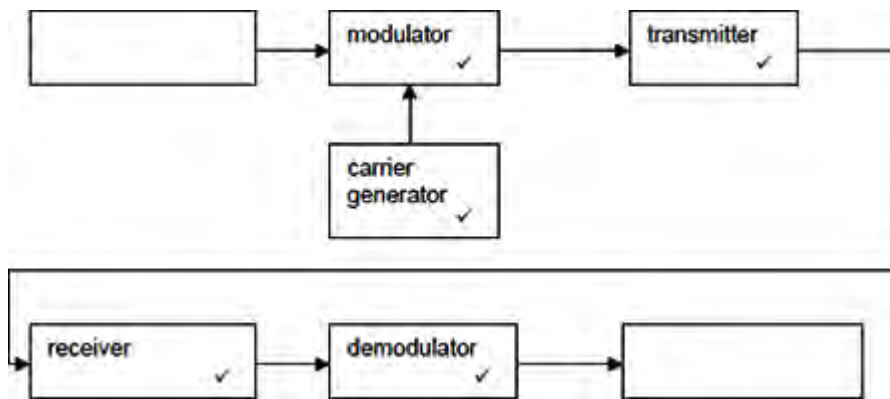

5

[8]